

Welding Neck Flanges PN 16

TS ISO 7005-1 - EN 1092-1

Tip 11 / Type 11

DIN 2633

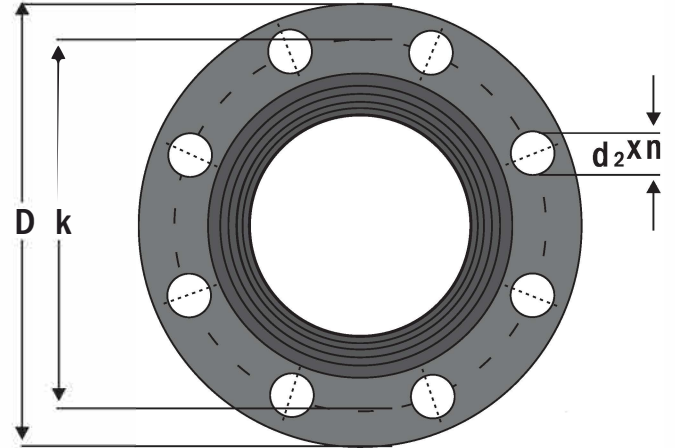
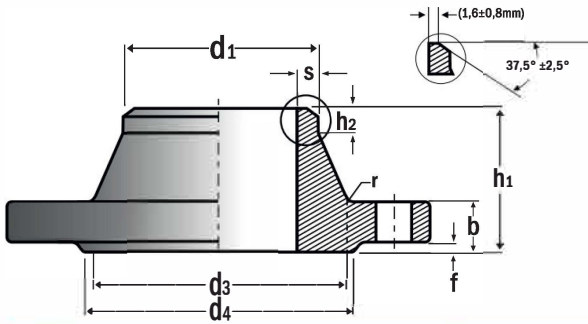

| PIPE DN | FLANGE | | | | NECK | | | | Raised Face | | | | Drillings | | Weigh kg | | | | | | | |
|------------|--------------|--------------|------|-------------|-------------|------|-----|--------------|--------------|-------------|-------------|-------------|-------------|--------------|-------------|--------------|--------------|--------------|-------------|-------------|-------------|-------------|
| | d1 1092-1 | d1 7005-1 | D | b 1092-1 | b 7005-1 | k | h1 | d3 1092-1 | d3 7005-1 | S 1092-1 | S 7005-1 | r 1092-1 | r 7005-1 | h2 1092-1 | | h2 7005-1 | d4 1092-1 | d4 7005-1 | f 1092-1 | f 7005-1 | n 1092-1 | n 7005-1 |
| 10 | 17,2 | 17,2 | 90 | 16 | 14 | 60 | 35 | 28 | 28 | 1,8 | 2,3 | 4 | 3 | 6 | 40 | 41 | 2 | 2 | 4 | M12 | 14 | 0,58 |
| 15 | 21,3 | 21,3 | 95 | 16 | 14 | 65 | 38 | 32 | 32 | 2 | 3,2 | 4 | 3 | 6 | 45 | 46 | 2 | 2 | 4 | M12 | 14 | 0,648 |
| 20 | 26,9 | 26,9 | 105 | 18 | 16 | 75 | 40 | 40 | 40 | 2,3 | 3,2 | 4 | 4 | 6 | 58 | 56 | 2 | 2 | 4 | M12 | 14 | 0,952 |
| 25 | 33,7 | 33,7 | 115 | 18 | 16 | 85 | 40 | 46 | 46 | 2,6 | 3,2 | 4 | 4 | 6 | 68 | 65 | 2 | 2 | 4 | M12 | 14 | 1,14 |
| 32 | 42,4 | 42,4 | 140 | 18 | 18 | 100 | 42 | 56 | 56 | 2,6 | 3,6 | 4 | 4 | 6 | 78 | 76 | 2 | 2 | 4 | M16 | 18 | 1,69 |
| 40 | 48,3 | 48,3 | 150 | 18 | 18 | 110 | 45 | 64 | 64 | 2,6 | 3,6 | 6 | 6 | 8 | 88 | 84 | 2 | 2 | 4 | M16 | 18 | 1,86 |
| 50 | 60,3 | 60,3 | 165 | 18 | 20 | 125 | 45 | 74 | 74 | 2,9 | 2,9 | 6 | 6 | 8 | 102 | 99 | 2 | 2 | 4 | M16 | 18 | 2,53 |
| 65 | 76,1 | 76,1 | 185 | 18 | 20 | 145 | 45 | 92 | 92 | 2,9 | 2,9 | 6 | 6 | 10 | 122 | 118 | 2 | 2 | 8 | M16 | 18 | 3,06 |
| 80 | 88,9 | 88,9 | 200 | 20 | 20 | 160 | 50 | 105 | 110 | 3,2 | 3,2 | 6 | 6 | 10 | 138 | 132 | 2 | 2 | 8 | M16 | 18 | 3,7 |
| 100 | 114,3 | 114,3 | 220 | 20 | 22 | 180 | 52 | 131 | 130 | 3,6 | 3,6 | 8 | 8 | 12 | 158 | 156 | 2 | 2 | 8 | M16 | 18 | 4,62 |
| 125 | 139,7 | 139,7 | 250 | 22 | 22 | 210 | 55 | 156 | 158 | 4 | 4 | 8 | 8 | 12 | 188 | 184 | 2 | 2 | 8 | M16 | 18 | 6,3 |
| 150 | 168,3 | 168,3 | 285 | 22 | 24 | 240 | 55 | 184 | 184 | 4,5 | 4,5 | 10 | 10 | 12 | 212 | 211 | 2 | 2 | 8 | M20 | 22 | 7,75 |
| 200 | 219,1 | 219,1 | 340 | 24 | 24 | 295 | 62 | 234 | 234 | 6,3 | 6,3 | 10 | 10 | 16 | 268 | 266 | 2 | 2 | 8 | M20 | 22 | 11,3 |
| 250 | 273 | 273 | 395 | 26 | 26 | 350 | 68 | 292 | 288 | 6,3 | 6,3 | 12 | 10 | 16 | 320 | 319 | 2 | 2 | 12 | M20 | 22 | 14,7 |
| 300 | 323,9 | 323,9 | 445 | 26 | 26 | 400 | 68 | 342 | 342 | 7,1 | 7,1 | 12 | 10 | 16 | 370 | 370 | 2 | 2 | 12 | M20 | 22 | 17,4 |
| 350 | 355,6 | 355,6 | 505 | 26 | 26 | 460 | 68 | 385 | 390 | 7,1 | 8,8 | 12 | 10 | 16 | 430 | 429 | 2 | 2 | 16 | M20 | 22 | 23,6 |
| 400 | 406,4 | 406,4 | 565 | 26 | 26 | 515 | 72 | 440 | 440 | 7,1 | 8,8 | 12 | 10 | 16 | 482 | 480 | 2 | 2 | 16 | M24 | 26 | 28,6 |
| 450 | 457 | 457 | 615 | 28 | 28 | 565 | 72 | 488 | 488 | 7,1 | 10 | 12 | 12 | 16 | 532 | 530 | 2 | 2 | 20 | M24 | 26 | 31,5 |
| 500 | 508 | 508 | 670 | 28 | 28 | 620 | 75 | 542 | 540 | 7,1 | 11 | 12 | 12 | 16 | 585 | 582 | 2 | 2 | 20 | M24 | 26 | 38,1 |
| 600 | 610 | 610 | 780 | 28 | 34 | 725 | 80 | 642 | 640 | 7,1 | 12,5 | 12 | 12 | 18 | 685 | 682 | 2 | 2 | 20 | M27 | 30 | 44,6 |
| 700 | 711 | 711 | 895 | 30 | 30 | 840 | 80 | 746 | 746 | 8 | - | 12 | 12 | 18 | 800 | 794 | 2 | 5 | 24 | M27 | 30 | 62,4 |
| 800 | 813 | 813 | 1015 | 32 | 32 | 950 | 90 | 850 | 848 | 8 | - | 12 | 12 | 18 | 905 | 901 | 2 | 5 | 24 | M30 | 33 | 84,1 |
| 900 | 914 | 914 | 1115 | 34 | 34 | 1050 | 95 | 950 | 948 | 10 | - | 12 | 12 | 20 | 1005 | 1001 | 2 | 5 | 28 | M30 | 33 | 98,5 |
| 1000 | 1016 | 1016 | 1230 | 34 | 34 | 1160 | 95 | 1052 | 1050 | 10 | - | 16 | 12 | 20 | 1110 | 1112 | 2 | 5 | 28 | M33 | 36 | 115 |
| 1200 | 1219 | 1220 | 1455 | 38 | 38 | 1380 | 115 | 1256 | 1256 | 11 | - | 16 | 12 | 25 | 1330 | 1328 | 2 | 5 | 32 | M36 | 39 | 182 |
| 1400 | 1422 | 1420 | 1675 | 42 | 42 | 1590 | 120 | 1460 | 1460 | 12 | - | 16 | 12 | 25 | 1535 | 1530 | 2 | 5 | 36 | M39 | 42 | 248 |
| 1600 | 1626 | 1620 | 1915 | 46 | 46 | 1820 | 130 | 1666 | 1666 | 14 | - | 16 | 12 | 25 | 1760 | 1750 | 2 | 5 | 40 | M45 | 48 | 347 |
| 1800 | 1829 | 1820 | 2115 | 50 | 50 | 2020 | 140 | 1868 | 1866 | 15 | - | 16 | 15 | 30 | 1960 | 1950 | 2 | 5 | 44 | M45 | 48 | 430 |
| 2000 | 2032 | 2020 | 2325 | 54 | 54 | 2230 | 150 | 2072 | 2070 | 16 | - | 16 | 15 | 30 | 2170 | 2150 | 2 | 5 | 48 | M45 | 48 | 539 |
| 2200 | 2235 | 2220 | 2550 | 58 | 58 | 2440 | 160 | 2275 | 2275 | 18 | - | 18 | 18 | 35 | 2370 | 2370 | 2 | 6 | 52 | M52 | 56/55 | 658 |
| 2400 | 2438 | 2420 | 2760 | 62 | 62 | 2650 | 170 | 2478 | 2478 | 20 | - | 18 | 18 | 35 | 2570 | 2570 | 2 | 6 | 56 | M52 | 56/55 | 825 |
| 2600 | 2620 | 2620 | 2960 | 66 | 66 | 2850 | 180 | 2680 | 2680 | 22 | - | 18 | 18 | 40 | 2780 | 2780 | 2 | 6 | 60 | M52 | 56/55 | 979 |
| 2800 | 2820 | 2820 | 3180 | 70 | 70 | 3070 | 190 | 2882 | 2882 | 22 | - | 18 | 18 | 40 | 3000 | 3000 | 2 | 6 | 64 | M52 | 56/55 | 1156 |
| 3000 | 3020 | 3020 | 3405 | 75 | 75 | 3290 | 200 | 3085 | 3085 | 24 | - | 18 | 18 | 45 | 3210 | 3210 | 2 | 6 | 68 | M56 | 62/60 | 1156 |

Ölçüler mm.'dir. / Dimensions are in mm.