

Welding Neck Flanges PN 100

TS ISO 7005-1 - EN 1092-1

Tip 11 / Type 11

DIN 2637

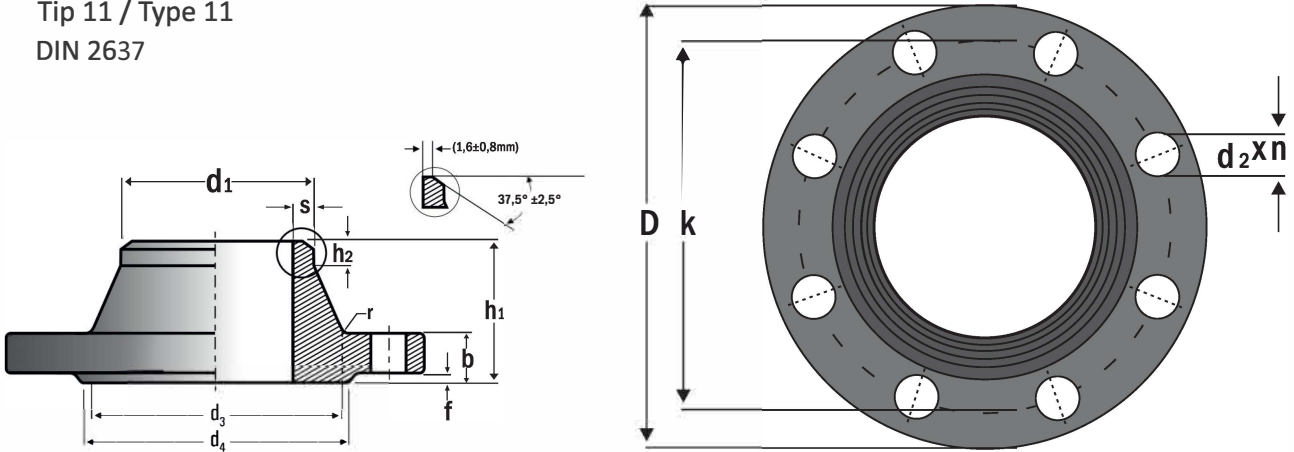

PIPE		FLANGE				NECK				Raised Face		Drillings		Weight	
DN	d1	D	b	k	h1	d3	s	r	h2	d4	f	n	screw	d2	kg
10	17,2	100	20	70	45	32	1,8	4	6	40	2	4	M12	14	1,09
15	21,3	105	20	75	45	34	2	4	6	45	2	4	M12	14	1,19
20	26,9	130	22	90	48	42	2,6	4	8	58	2	4	M16	18	
25	33,7	140	24	100	58	52	2,6	4	8	68	2	4	M16	18	2,66
32	42,4	155	24	110	60	62	2,9	6	8	78	2	4	M20	22	
40	48,3	170	26	125	62	70	2,9	6	10	88	2	4	M20	22	4,09
50	60,3	195	28	145	68	90	3,2	6	10	102	2	4	M24	26	5,98
65	76,1	220	30	170	76	108	3,6	6	12	122	2	8	M24	26	7,91
80	88,9	230	32	180	78	120	4	8	12	138	2	8	M24	26	8,95
100	114,3	265	36	210	90	150	5	8	12	162	2	8	M27	30	13,7
125	139,7	315	40	250	105	180	6,3	8	12	188	2	8	M30	33	22,7
150	168,3	355	44	290	115	210	7,1	10	12	218	2	12	M30	33	30,2
200	219,1	430	52	360	130	278	10	10	16	285	2	12	M33	36	52,8
250	273	505	60	430	157	340	12,5	12	18	345	2	12	M36	39	81,4
300	323,9	585	68	500	170	400	14,2	12	18	410	2	16	M39	42	122
350	355,6	655	74	560	189	460	16	12	20	465	2	16	M45	48	165

Ölçüler mm.'dir. / Dimensions are in mm.